

## ACCUENERGY Canada

### Multi-Function Power Meter



UL & cUL Certified



Accuracy Class 0.5s & 0.2s



Front Panel Protection IP54



Power Quality Analysis



Over/Under Limit Alarming



MAX & MIN Record



Input & Output Modules



Multi-circuit metering system

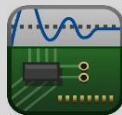

Up To 16MB Internal Memory



We Can Provide a Ready To Use Complete Metering Solution



Yes we can ... As we aware

Sales@Acfet-eg.com

# Energy Management System

## Free Data logging software

- ❖ PC software interface provides a simple tool for Remote real time monitoring & setting

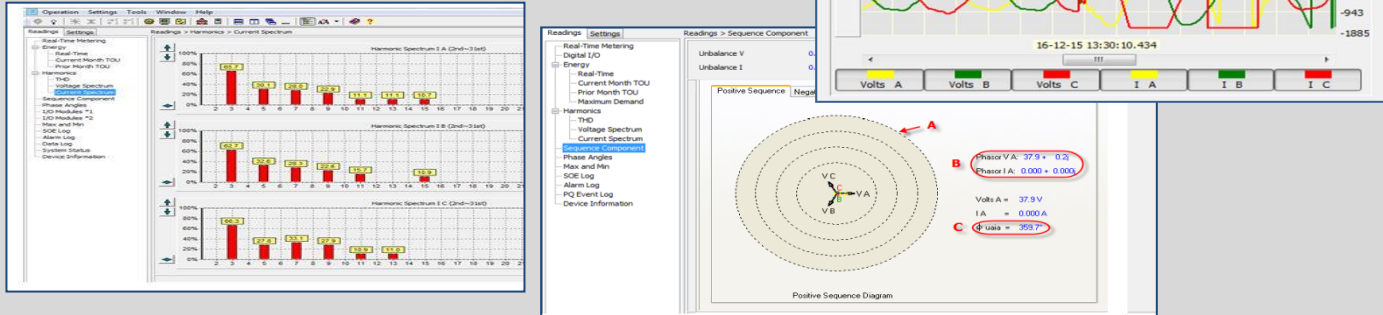

## Network communication

- ❖ Worldwide monitoring Via WEB modules

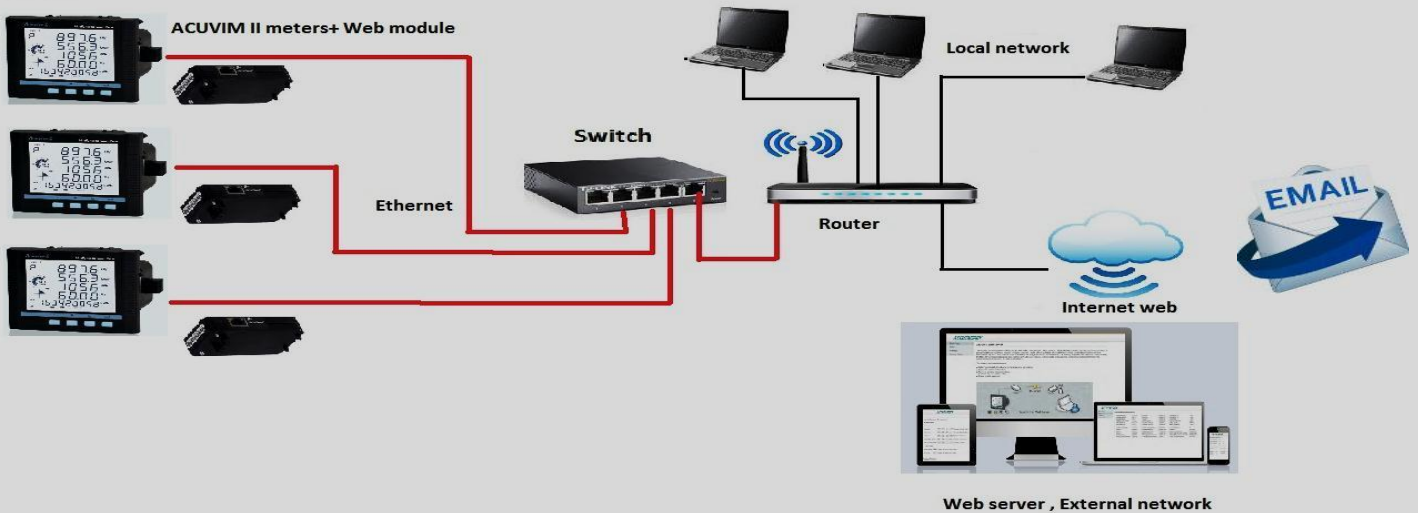

## Web Based Professional Software

- ❖ real time energy monitoring, measurement and reporting
- ❖ Detect energy saving opportunities



Yes we can ... As we aware

Sales@Acfet-eg.com



**NEWTEK ELECTRICALS** INDIA

## Digital Meters

- ❖ Measure VL-N, VL-L, I line, I n, P, Q, S PF, F, Max P\_demand, Ep, Eq, Es
- ❖ Compact size and reading with highest brightness



## Current transformers

- ❖ Measurement and protection type CT's
- ❖ Nylon flame retardant casing
- ❖ Wide measuring range up to 6 KA primary current
- ❖ Accuracy class 0.2, 0.5 & 1 on request & up to 20 VA
- ❖ Light weight due to high magnetic core material





## MV voltage and current transformers

- ❖ Current transformer operating voltage up to 36 KV
- ❖ Rated primary current up to 4000A / 5A or 1A
- ❖ Accuracy class 0.2-0.5- 1.0 with rated burden 5 – 10- 15- 20- 30- 40 VA

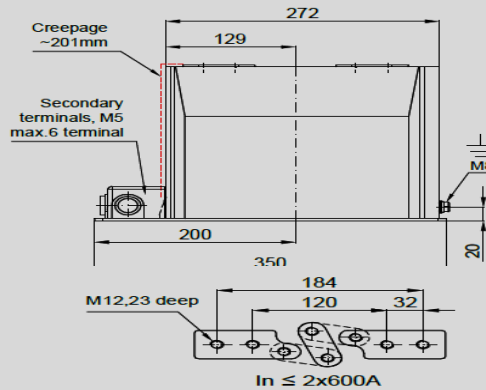

## Electrical Power transducers

- ❖ AC/DC Single and three phase network analyzer
- ❖ Measurement of Irms, Vrms, Watt, Var, Frequency, Cosφ,, Energy, THD, min and Max of all RMS measurement
- ❖ Output 0/4-20 mA / 0-10 V standard analog signal
- ❖ RS-485 Modbus communication and alarm contact output

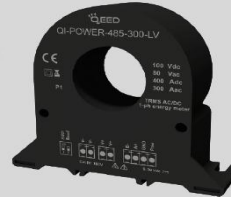

# Monitoring System

## Signal Sensors

- ❖ Temperature sensors (RTDs, TC, NTC, PTC ...)
- ❖ All mounting types (air, duct, wall ...)
- ❖ Field signal transmitters (Pressure, Humidity, Level, flow, speed ...)

## Signal Recorders

- ❖ Up to 48 Channels
- ❖ Expansion modules of input & output
- ❖ Internal flash memory up to 256 MB
- ❖ Historical & real time viewer software



## Digital Indicators

- ❖ Universal Signal indicator & totalizer
- ❖ 4, 6, 8 display digit
- ❖ Alarm relay output
- ❖ Analog signal transmission

## Scada monitoring system

- ❖ Monitoring SCADA system
- ❖ Alarming system
- ❖ Control & management system

# Monitoring System

## Sensing

Sensing elements for all physical quantities (Temp, pressure, humidity, flow, speed,...etc.)

High accuracy & quality sensing elements

Mounting: air, duct, wall...etc.

With/ without display

Proximity, PNP, Namur, photoelectric ...

Transmitters for (Temp, humidity, etc.) sensors



## Indicating



High performance compact panel indicators for continuous monitoring of all your system signals



Universal Analog/Digital input indicators

Bar graph indicators – totalizer function

Available 4, 6, 8, 11 digits displays

Plug & play Configurator software

Alarm outputs & retransmission signals

# Monitoring System

## Recording

**BrainChild Taiwan**  
BRAINCHILD ELECTRONIC CO., LTD THE HEART OF ASIA

Recorders with expandable input/output modules up to 48 channels

Panel mounted paper & paperless recorders

Math, Counter, Totalizer functions

High resolution touch screen

Historical & real time viewer

Bar graph, Chart & Digits display

Ethernet port TCP/IP Web server, Email



## Scada

**MIKRODEV** Akülü Kontrolde Teknoloji Devisi TURKEY

**BrainChild Taiwan**  
BRAINCHILD ELECTRONIC CO., LTD THE HEART OF ASIA

SCADA is the solution for industrial automation. It enables you to achieve monitoring and controlling your plant operation remotely



Compatible with Windows, Linux & MacOS

Events and alarms real/history monitoring

WIFI, GSM & Ethernet connection

Advanced SCADA editor

Users with different authorization levels

PLC+HMI combined with I/O modules



## Signal converters

- ❖ Universal analog/digital input signal converter
- ❖ Data logging via USB into standard csv files
- ❖ Accuracy class 0.1 % FS
- ❖ Analog / Digital/ Relay output
- ❖ AC/DC power supply
- ❖ Approval CE, UL-CSA



## Special converters

- ❖ Universal Analog signal duplicator (splitter)
- ❖ 2 analog signals adder/subtractor
- ❖ Single, Double & Triple Trip alarm modules
- ❖ Universal current / voltage converter and analyzer
- ❖ Compact Signal Converters isolators (6.2 thickness) mm

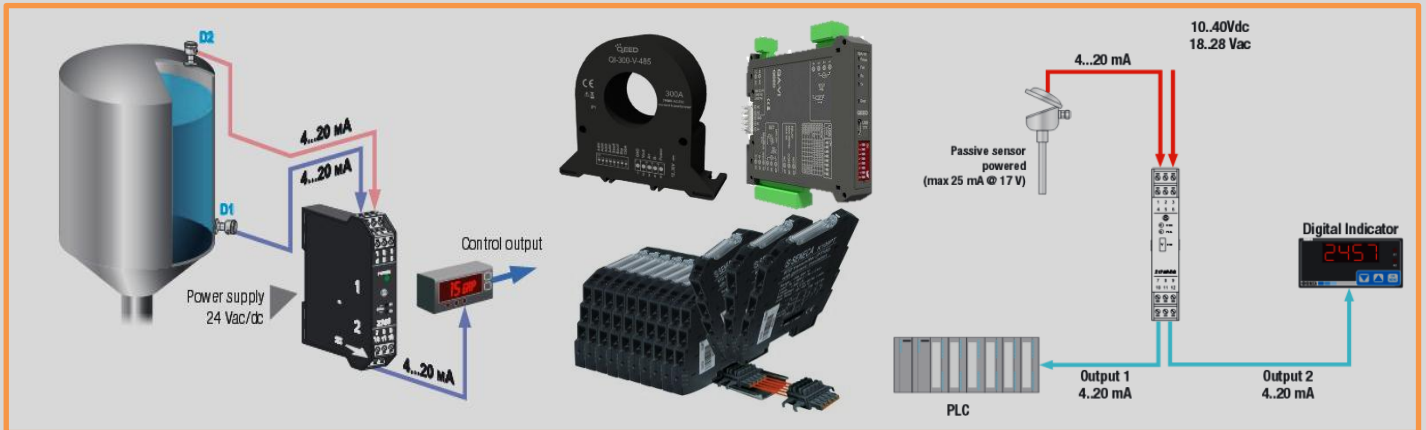

## Process controller



- ❖ Different control forms (On/Off, PID, Fuzzy PID).
- ❖ Accepting different process input signals.
- ❖ Different outputs (Relays, SSR drive, Analog signals).
- ❖ Availability of communication ports.





# Signal Management

Control system **MIKRODEV**  
Akülü Kontrolde Teknoloji Devri **TURKEY**

PLC control system is cost effective solution for automation systems

- ❖ Easy programming using FBD interface
- ❖ Digital & Analog inputs / outputs
- ❖ Expansion modules up to 640 DI/O and 96 AI/O
- ❖ PID, auto-tuning feature and analog mathematical operations
- ❖ Remote monitoring & control for distributed systems (RTU- SCADA systems)
- ❖ WI-FI modem, GSM (SMS send/receive, accept calls, make calls )

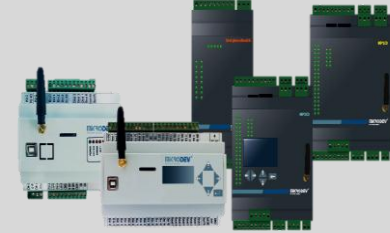
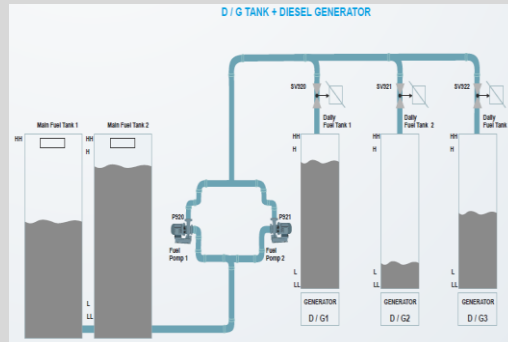
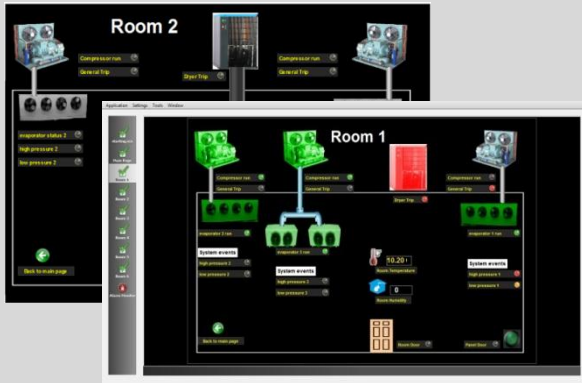
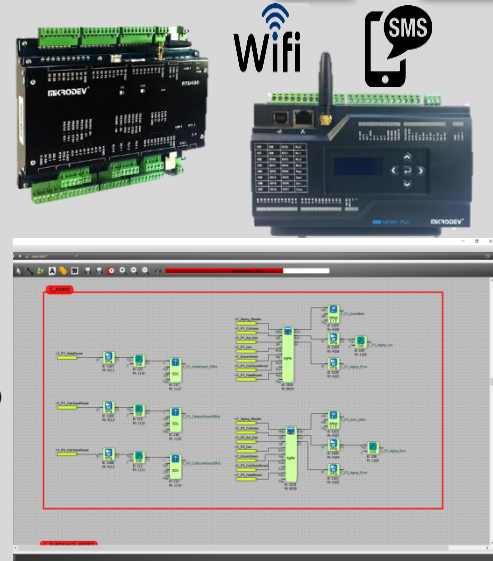

EED  
SENECA ITALY  
AUTOMATION INTERFACES  
BrainChild Taiwan  
BRAINCHILD ELECTRONIC CO., LTD THE HEART OF ASIA

## I/O's & Communication Modules

- ❖ I/O slave Modbus RTU system (multichannel)
- ❖ I/O modules (universal AI, universal DI, AO, DO, RO ...etc.)
- ❖ Isolated serial converters
  - MODBUS RTU/TCP-IP
  - Bluetooth to RS485 Repeater
  - RS485-USB

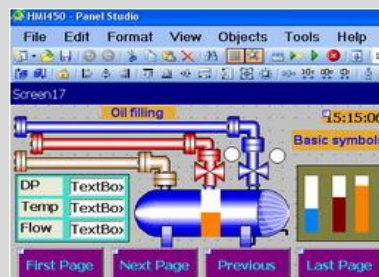
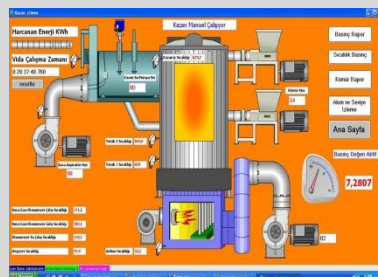
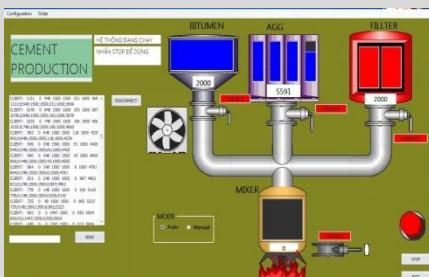
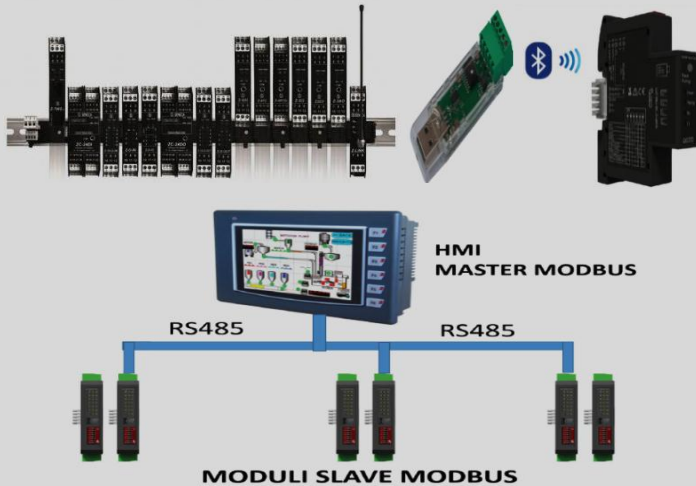

**ACFET** Company supplies a wide range of products.

- ❖ Panel components (Circuit breakers, Contactors, Over loads, Timers, Protection relays, Terminal blocks, Bus bar isolators, Cable glands, Cable lugs, Indication Lamps, Push buttons, Selector switch...etc.)
- ❖ AC induction motors, Vibrator motors, Geared motors, Gear boxes and Motor speed drives.
- ❖ Ball valves, Gate valves, Butterfly valves, Globe valves & Solenoid valves.
- ❖ Pneumatic equipment, Cylinders & Air filter regulators.
- ❖ Gas equipment (Pressure regulators, Pressure switches, Solenoid valves, Gas detectors, Gas filters, Safety Valves ...etc.).
- ❖ Hoses, Steam traps, Expansion joints, Level control gauge for boilers ...etc.

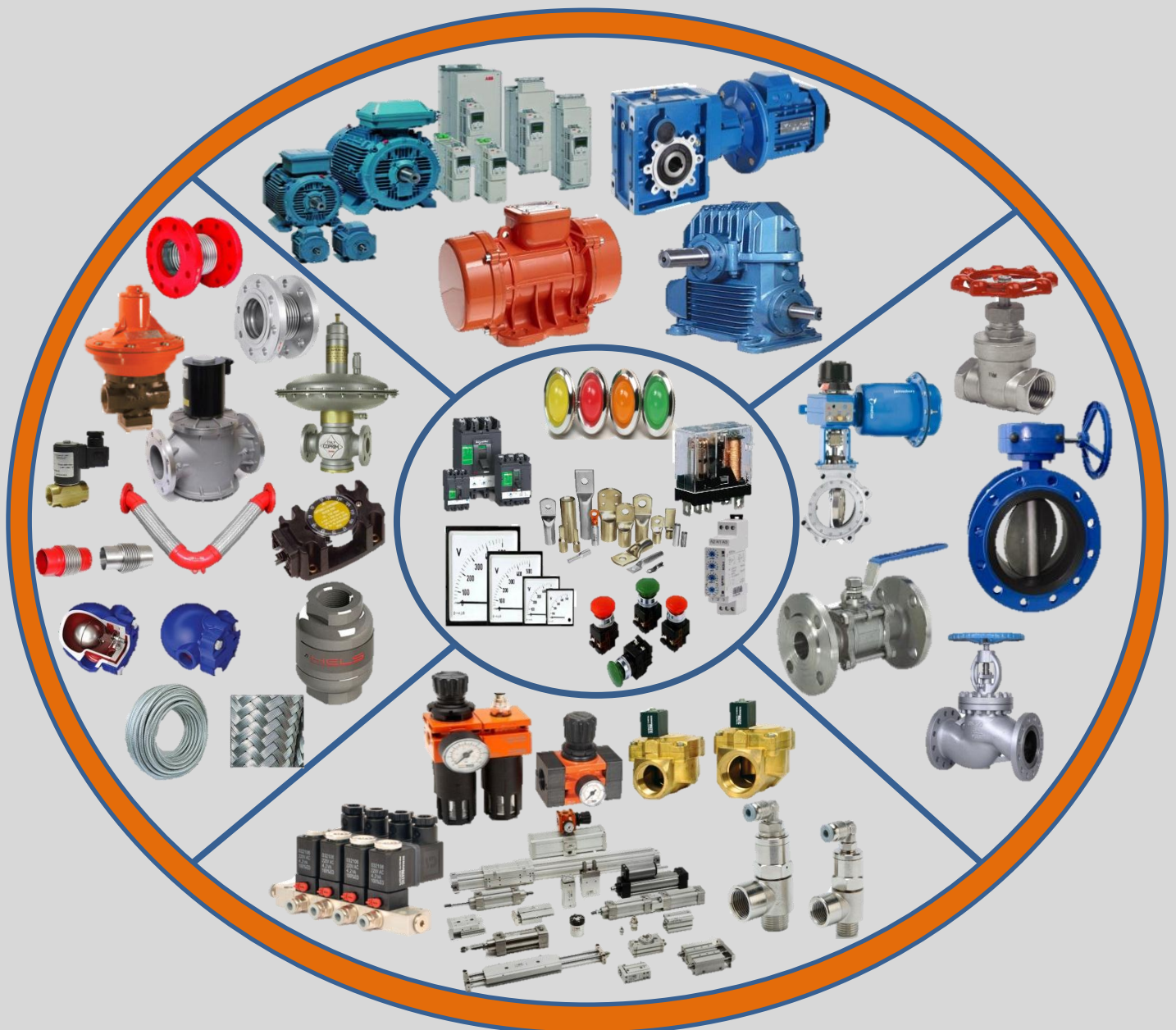

# Projects

**ACFET** is certified from "The Egyptian Federation for Construction & Building Contactors" as Electro-Mechanical Contractor with high capabilities to execute the electromechanical works with high performance and quality.

**Awareness** of the past, present and future trends enable us to perform tasks best suited to the objectives of the clients.



## ❖ Electrical installation works

Our expert's team can provide design and engineering support to ensure the services in your project are working at their best. They are qualified in a wide range of construction and engineering disciplines and will help ensure quality projects are completed on time and to budget.

- ❖ Planning, Designing and Engineering Services.
- ❖ Installation, Testing & commissioning Services.
- ❖ Operational & Maintenance Services.



We have a team-oriented engineering and solutions firm where everyone lends their skills and expertise to develop the best outcome for engineering documents including conceptual designs, construction drawings, details, schedules, and as-built drawings.

Our team of high skilled professionals fully equipped with tools, test equipment and vehicles are available all the time to respond and ensure that any downtime or disruption will be kept minimum.

## ❖ Motor control center MCC panels

All types (star/delta, soft starter, motor speed drive... etc.)



## ❖ Control Panels



We are devoted to providing the best engineering services available to meet the needs of your project in every possible way.

# Contacts

Contact us for any support



[www.acfet-eg.com](http://www.acfet-eg.com)



[www.facebook.com/acfet.egypt](http://www.facebook.com/acfet.egypt)



+2012102033785

## Administration Department

[info@acfet-eg.com](mailto:info@acfet-eg.com)

## Sales Department

[sales@acfet-eg.com](mailto:sales@acfet-eg.com)

## Sales Support Department

[support@acfet-eg.com](mailto:support@acfet-eg.com)

## Development Department

[development@acfet-eg.com](mailto:development@acfet-eg.com)

## Your Direct Contact

*Business Card*

## Notes

## About Us

- ❖ Awareness Company For Engineering & Trading “ACFET” is an Electro-Mechanical Supplier & Contractor.
- ❖ Although ACFET was founded in 2013 but it based on more than 25 years’ experience in the Egyptian market due to its founders background.
- ❖ Since it's born “ACFET” was a very fast grown company depending in that on providing its customers with the high quality products and services which reflected with a very good reputation in the market and a very strong relation with the customers.

## Our Vision

From our company name, we took our vision, as we believe that we are **AWARE** of what our customers need and we are looking forward to be one of the leading companies in our field by being more aware of more and more customers’ needs and by satisfying these needs.

## Our Mission

To provide our customer with a high quality products and services in a way that not only satisfies his needs but, satisfy his desires.

## Company Structure

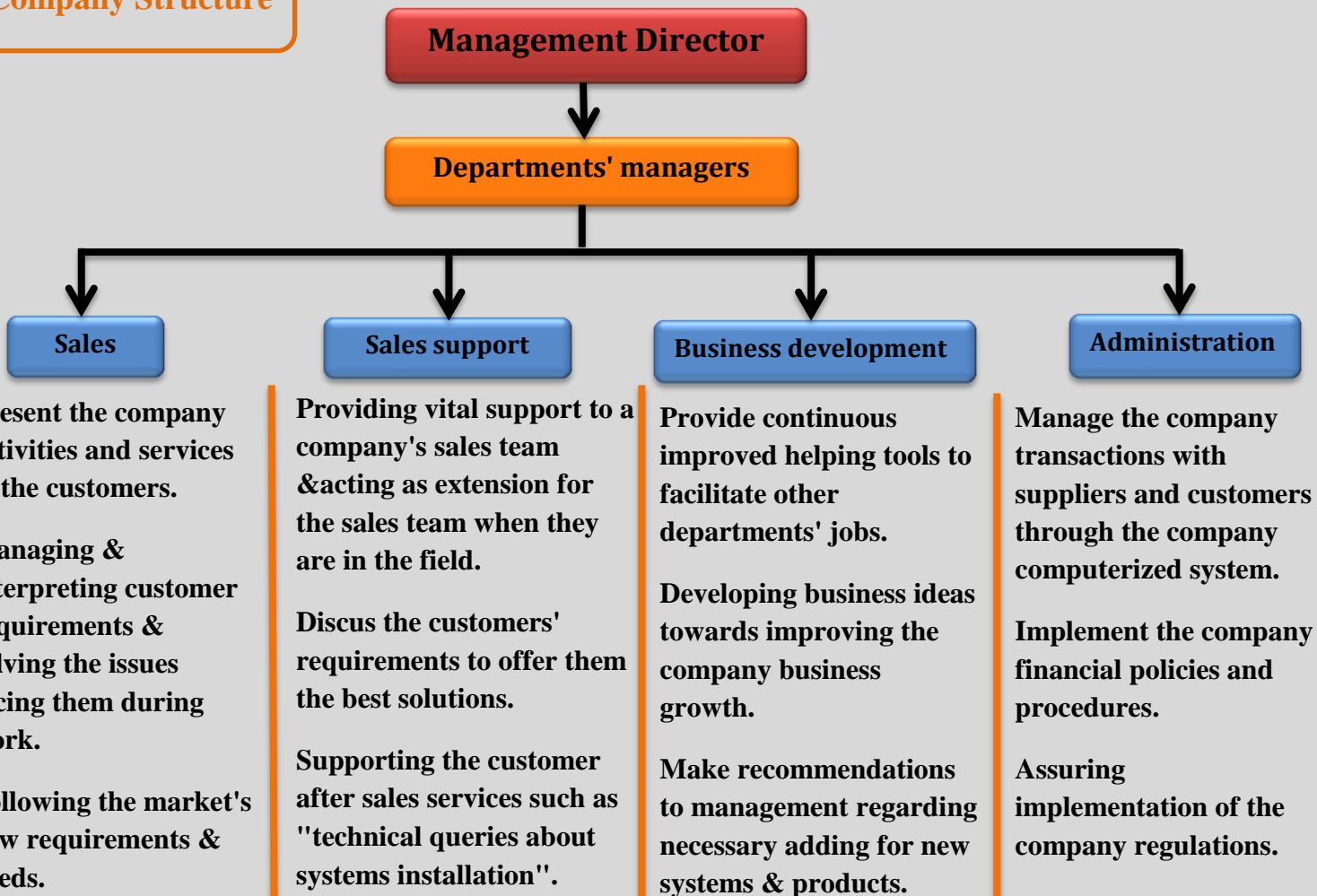

## Our Reference

We are proud to serve those well-known companies who are relying on us.



It will be our honor to add your Logo to our Reference List

Yes we can ... As we aware

Sales@Acfet-eg.com